

4

3

2

1

THIS DRAWING IS UNPUBLISHED. RELEASED FOR PUBLICATION ,19 .
 © COPYRIGHT 19 BY AMP INCORPORATED. ALL RIGHTS RESERVED.

LOC	DIST	REVISIONS					
		P	LTR	DESCRIPTION	DATE	DWN	APVD
G	14		J	REVISE PER ECN 0G10-0114-98	10AUG98	SU	MB

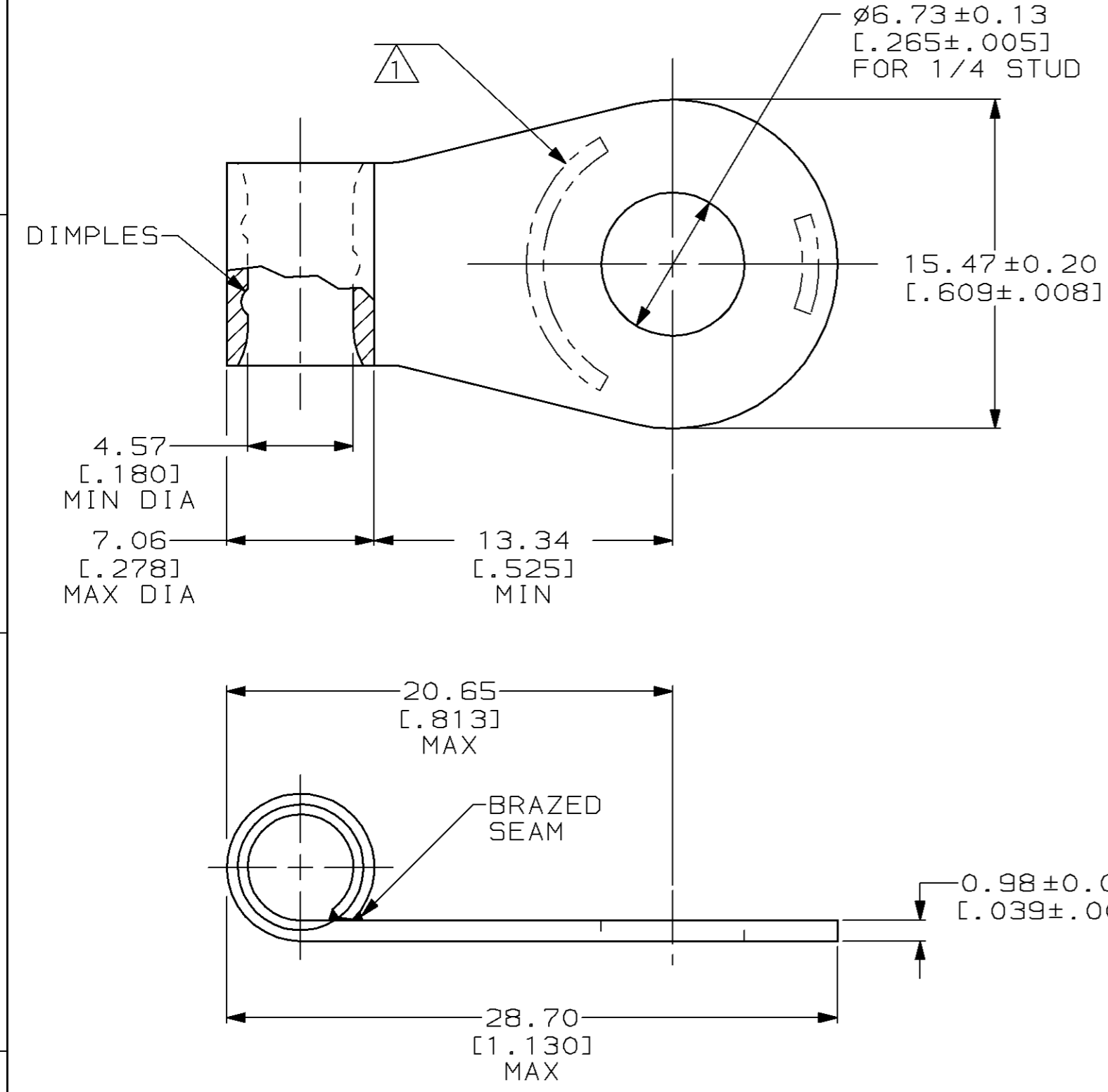

AMP WIRE RANGE	E13288 Listed
8 AWG SOLID OR STRANDED	8 AWG STRANDED
LR7189 Certified	MILITARY P/N AND CLASS
8 AWG SOLID OR STRANDED	NOT APPLICABLE

- ① STAMP AMP 8W* APPROX AS SHOWN.
- ② TIN PLATE 0.00254 [.000100] MIN THICK PER ASTM B-545.
- ③ NICKEL PLATE 0.00762 [.000300] MIN THICK PER QQ-N-290.
- ④ NOT UL LISTED OR CSA CERTIFIED.

③	322727-1	④
②	322727	
FINISH	PART NUMBER	

AMP INCORPORATED
CUSTOMER SERVICE SYSTEMS

FOR ADDITIONAL PRODUCT INFORMATION OR COPIES OF DRAWINGS AND TECHNICAL DOCUMENTS
 PRODUCT INFORMATION CENTER
 1-800-522-6752

FOR APPLICATION TOOLING INFORMATION
 TOOLING ASSISTANCE CENTER
 1-800-722-1111

FOR ORDER ENTRY
 1-800-526-5142

RECOMMENDED OPERATING TEMPERATURE:
 170°C MAX

VOLTAGE RATING:
 NOT APPLICABLE

WIRE CROSS SECTIONAL AREA RANGE:
 6.64-10.54mm² [13,100-20,800] CIR MILS
 SOLID OR STRANDED

THIS DRAWING IS A CONTROLLED DOCUMENT FOR AMP INCORPORATED. IT IS SUBJECT TO CHANGE AND THE CONTROLLING ENGINEERING ORGANIZATION SHOULD BE CONTACTED FOR THE LATEST REVISION.

DIMENSIONS: mm [INCHES]	TOLERANCES UNLESS OTHERWISE SPECIFIED:
	0 PLC ±-
	1 PLC ±-
	2 PLC ±-
	3 PLC ±-
	4 PLC ±-
	ANGLES ±-
MATERIAL COPPER PER ASTM B-152 ANNEALED	FINISH SEE NOTES

DWN DK SCHRUM 11 JUN 97	AMP AMP Incorporated Harrisburg, PA 17105-3608
CHK MJ SPICER 12 JUN 97	
APVD JL MECKLEY 12 JUN 97	
PRODUCT SPEC	
APPLICATION SPEC	NAME TERMINAL, RING TONGUE, FLAG, SOLISTRAND™
WEIGHT -	SIZE A3
CUSTOMER DRAWING	CAGE CODE 00779
	DRAWING NO C-322727
	SCALE 4:1
	SHEET 1 OF 1
	REV J